

## Instruction Sheet No.5010

Revised 1-12-99

Copyright © 1998, 1999  
by S&S Cycle, Inc.  
All rights reserved. Printed in the U.S.A.

# S&S Cycle, Inc.

14025 County Hwy. G P.O. Box 215

Viola, Wisconsin 54664

Phone 608-627-1497 Fax 608-627-1488

Customer Service - sscust@sscycle.com

Technical Assistance - sstech@sscycle.com



## S&S Balance Kit Instructions

### Introduction

The S&S balancing kit is designed to allow the engine builder to statically balance each flywheel separately in the H-D Big Twin® and Sportster® engines. The static method of balancing uses gravity to cause the heaviest part of the flywheel to rotate downwards when placed on the balance stand. Weight is then removed from the heavy side by drilling holes. When the flywheel no longer rotates, it is in balance.

The object of balancing the flywheels is to minimize engine vibration which improves performance and riding comfort and avoids damage to engine and chassis components. Usually the rider is quick to blame engine flywheel imbalance as the cause of the problem. We have found that the problem often lies elsewhere.

Improper engine installation in the frame, poor engine and transmission sprocket alignments, flywheels not properly trued, tires out of balance, faulty frame design, poorly balanced stator and/or clutch hub, worn primary drive chain, and rigidly mounted handlebars are a few areas that can cause vibrations often blamed on flywheel balance. Improper installation of the engine in the frame and other chassis components that are bolted on the frame sometimes form a resonant effect resulting in vibration at certain rpms. This explains why an engine which runs smoothly in one frame may vibrate when placed in another frame with different forks. Only after investigating all of these other areas should the engine be checked.

The 45° design of the H-D engine makes it difficult to obtain perfect flywheel balance that will make the motorcycle vibration free at all rpms. The goal is to make the motorcycle as vibration free as possible and perform the best in the rpm range where the most riding is done. If the engine is used exclusively for drag racing, it may be desirable to balance for higher rpm ranges - say 3000 rpm upward. Most street riders run their engines in the 2000 rpm to 5000 rpm range most of the time.

#### IMPORTANT NOTICE:

Statements in this instruction sheet preceded by the following words are of special significance:

#### WARNING

Means there is the possibility of injury to yourself or others.

#### CAUTION

Means there is the possibility of damage to the carburetor or motorcycle.

#### NOTE

*Other information of particular importance has been placed in italic type.*

**S&S recommends you take special notice of these items.**

The balance factor we use and recommend is 60%. We arrived at this percentage after much experimentation, and found it to give the best results over the rpm range that riders most commonly use. Factors other than 60% will change the direction and amplitude of vibration. For example, if the balance factor is 50% or less, the engine will tend to vibrate vertically. As the percentage is increased, this vertical motion changes to horizontal motion. Horizontal motion from our experiments is more acceptable with less noticeable vibration transmitted to the rider. Therefore, 60% is the percentage S&S uses as a compromise for best all around performance and riding comfort.

### Balance Formula

The components which must be compensated for when balancing H-D flywheels are placed in two categories.

**Reciprocating Parts** - Reciprocating parts are those parts which travel in a reciprocating (up and down) motion. These are the pistons, piston rings, wristpins, wristpin clips and the wristpin ends of the connecting rods. The total weight of the reciprocating parts equals the reciprocating weight.

**Rotating Parts** - Rotating parts are those which move in a circular motion. The crankpin, crankpin nuts, bearings, bearing cages, nut locks and screws, and crankpin end of both connecting rods are rotating parts whose weights when added together equal the rotating weight.

The balance formula used to calculate the weight of the bobweight that must be bolted into each flywheel is:

$$\text{Weight of bobweight per Flywheel} = \frac{(60\% \times \text{reciprocating weight}) + (100\% \times \text{rotating weight})}{2}$$

Note that S&S uses 60% of the reciprocating weight. When we speak of the "balance factor", we usually refer to the percentage of the total reciprocating weight used in balance calculations.

### Balancing Procedure

Perform following steps to balance flywheels:

#### 1. Weigh Parts

All reciprocating and rotating parts to be used must be weighed and recorded to calculate weight of bobweight. For greatest accuracy S&S recommends using gram scale. Weigh and record weight of:

- Front piston.
- Front piston wristpin.
- Front piston wristpin clips/buttons.

- D. Front piston rings.
- E. Repeat steps A through D for rear piston.

NOTE - Weighing parts separately allows for direct comparisons of parts in event parts are replaced at some later time.

- F. Crankpin.
- G. Crankpin nuts.
- H. Crankpin key.
- I. Bearing cages.
- J. Bearings.
- K. Small end of front rod. **See Figure 1** for correct positioning to weigh connecting rod.

NOTE - To get correct weight of each end of rod, centerline of rod must be level horizontally when pointer of scale is at zero position. Eyeball rod position and adjust rod support stand accordingly. A card with horizontal lines placed behind scale makes leveling of rods easier. Rest edge of rod that exhibits smoother contours on platform and rod support stand. Grinding marks and/or forging seam lines may cause unwarranted friction which may distort actual balance weight of rod.

- L. Big end of front rod.
- M. Complete front rod.

NOTE - Purpose of obtaining total weight of each connecting rod is to compare sum weight derived from adding weights of each end to actual total weight of rod and then adjust each end accordingly. If actual weight is more or less than sum by **6 or more grams**, each end of rod must be reweighed. If actual weight is more or less than sum by **less than 6 grams**, two thirds of

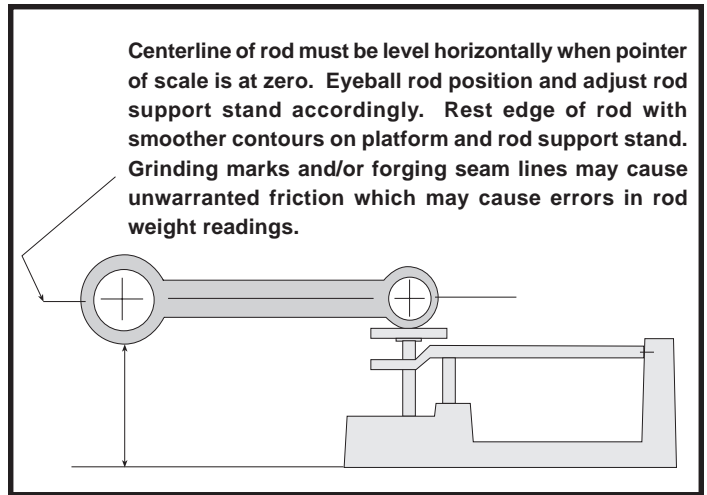

Figure 1

difference is added to or subtracted from crankpin end weight and one third of the difference is added to or subtracted from wristpin end weight.

A 2:1 ratio of crankpin end to wristpin end is used, because crankpin end is approximately twice as heavy as wristpin end of rod. Example: Actual weight of rear rod equals 600 grams and sum of each end together equals 605.4 grams. Difference equals 5.4 grams and must be subtracted from rod end weights. Difference divided by 3 equals 1.8. Subtract 3.6 grams (1.8 grams X 2) from

**Owner's Name:** John Doe -- 1234 Harley Street -- Milwaukee, WI

<p><b>Date:</b> <u>3-24-94</u></p> <p><b>Big Twin</b> <input checked="" type="checkbox"/> <b>Sportster</b> <input type="checkbox"/></p> <p><b>Year of Engine</b> <u>1987</u></p> <p><b>Bore</b> <u>3 1/2" + .005</u></p> <p><b>Stroke</b> <u>4 5/8"</u></p> <p><b>Rod Type</b> <u>S&amp;S 7100</u></p> <p><b>Cage Type</b> <u>Alloy</u></p>	<p><b>Front Piston Weight</b></p> <table style="width: 100%; border-collapse: collapse;"> <tr><td>Piston</td><td style="text-align: right;">400</td></tr> <tr><td>Wristpin</td><td style="text-align: right;">100</td></tr> <tr><td>Clips</td><td style="text-align: right;">5</td></tr> <tr><td>Rings</td><td style="text-align: right;">40</td></tr> <tr><td><b>Total</b></td><td style="text-align: right;"><b>545</b></td></tr> </table> <p><b>Rear Piston Weight</b></p> <table style="width: 100%; border-collapse: collapse;"> <tr><td>Piston</td><td style="text-align: right;">395</td></tr> <tr><td>Wristpin</td><td style="text-align: right;">100</td></tr> <tr><td>Clips</td><td style="text-align: right;">5</td></tr> <tr><td>Rings</td><td style="text-align: right;">40</td></tr> <tr><td><b>Total</b></td><td style="text-align: right;"><b>540</b></td></tr> </table> <p><b>Total of Both</b> <u>1085</u></p>	Piston	400	Wristpin	100	Clips	5	Rings	40	<b>Total</b>	<b>545</b>	Piston	395	Wristpin	100	Clips	5	Rings	40	<b>Total</b>	<b>540</b>	<p><b>Connecting Rods</b></p> <table style="width: 100%; border-collapse: collapse;"> <tr><td>Crankpin</td><td style="text-align: right;">550</td></tr> <tr><td>Nuts</td><td style="text-align: right;">80</td></tr> <tr><td>Cages</td><td style="text-align: right;">30</td></tr> <tr><td>Bearings</td><td style="text-align: right;">40</td></tr> <tr><td>Nut Locks &amp; Screws</td><td style="text-align: right;"><i>Not used</i></td></tr> <tr><td><b>Total</b></td><td style="text-align: right;"><b>700</b></td></tr> </table> <p><b>Front Rod</b></p> <table style="width: 100%; border-collapse: collapse;"> <tr><td>WP End</td><td style="text-align: right;">209</td></tr> <tr><td>CP End</td><td style="text-align: right;">381</td></tr> <tr><td><b>Total</b></td><td style="text-align: right;"><b>590</b></td></tr> <tr><td><b>Act. Wt.</b></td><td style="text-align: right;"><b>590</b></td></tr> </table> <p><b>Rear Rod</b></p> <table style="width: 100%; border-collapse: collapse;"> <tr><td>WP End</td><td style="text-align: right;">204</td></tr> <tr><td>CP End</td><td style="text-align: right;">481</td></tr> <tr><td><b>Total</b></td><td style="text-align: right;"><b>685</b></td></tr> <tr><td><b>Act. Wt.</b></td><td style="text-align: right;"><b>685</b></td></tr> </table>	Crankpin	550	Nuts	80	Cages	30	Bearings	40	Nut Locks & Screws	<i>Not used</i>	<b>Total</b>	<b>700</b>	WP End	209	CP End	381	<b>Total</b>	<b>590</b>	<b>Act. Wt.</b>	<b>590</b>	WP End	204	CP End	481	<b>Total</b>	<b>685</b>	<b>Act. Wt.</b>	<b>685</b>	<p><b>Reciprocating Weight</b></p> <table style="width: 100%; border-collapse: collapse;"> <tr><td><b>Total of Both Pistons</b></td><td style="text-align: right;"><b>1085</b></td></tr> <tr><td>WP End of Front Rod</td><td style="text-align: right;">209</td></tr> <tr><td>WP End of Rear Rod</td><td style="text-align: right;">204</td></tr> <tr><td><b>Total Reciprocating Weight</b></td><td style="text-align: right;"><b>1498</b></td></tr> </table> <p><b>Rotating Weight</b></p> <table style="width: 100%; border-collapse: collapse;"> <tr><td><b>Total of Crankpin, Nuts, etc.</b></td><td style="text-align: right;"><b>700</b></td></tr> <tr><td>CP End of Front Rod</td><td style="text-align: right;">381</td></tr> <tr><td>CP End of Rear Rod</td><td style="text-align: right;">481</td></tr> <tr><td><b>Total Rotating Weight</b></td><td style="text-align: right;"><b>1562</b></td></tr> </table> <p><b>Total Reciprocating Weight</b> <u>1498</u></p> <p><b>Multiply Times Balance Factor</b> <u>.60</u></p> <p><b>Reciprocating Weight</b> <u>898.8</u></p> <p><b>Add Total Roating Weight</b> <u>1562.0</u></p> <p><b>Total Bobweight for 2 Wheels</b> <u>2460.8</u></p> <p><b>Divide By 2</b> <u>÷ 2</u></p> <p><b>Total Weight of Bobweight to Be Used on Each Flywheel</b> <u>1230.4</u></p>	<b>Total of Both Pistons</b>	<b>1085</b>	WP End of Front Rod	209	WP End of Rear Rod	204	<b>Total Reciprocating Weight</b>	<b>1498</b>	<b>Total of Crankpin, Nuts, etc.</b>	<b>700</b>	CP End of Front Rod	381	CP End of Rear Rod	481	<b>Total Rotating Weight</b>	<b>1562</b>
Piston	400																																																																		
Wristpin	100																																																																		
Clips	5																																																																		
Rings	40																																																																		
<b>Total</b>	<b>545</b>																																																																		
Piston	395																																																																		
Wristpin	100																																																																		
Clips	5																																																																		
Rings	40																																																																		
<b>Total</b>	<b>540</b>																																																																		
Crankpin	550																																																																		
Nuts	80																																																																		
Cages	30																																																																		
Bearings	40																																																																		
Nut Locks & Screws	<i>Not used</i>																																																																		
<b>Total</b>	<b>700</b>																																																																		
WP End	209																																																																		
CP End	381																																																																		
<b>Total</b>	<b>590</b>																																																																		
<b>Act. Wt.</b>	<b>590</b>																																																																		
WP End	204																																																																		
CP End	481																																																																		
<b>Total</b>	<b>685</b>																																																																		
<b>Act. Wt.</b>	<b>685</b>																																																																		
<b>Total of Both Pistons</b>	<b>1085</b>																																																																		
WP End of Front Rod	209																																																																		
WP End of Rear Rod	204																																																																		
<b>Total Reciprocating Weight</b>	<b>1498</b>																																																																		
<b>Total of Crankpin, Nuts, etc.</b>	<b>700</b>																																																																		
CP End of Front Rod	381																																																																		
CP End of Rear Rod	481																																																																		
<b>Total Rotating Weight</b>	<b>1562</b>																																																																		

**NOTES:**

	<i>Front Rod</i>		<i>WP</i>	<i>CP</i>		<i>Rear Rod</i>		<i>WP</i>	<i>CP</i>	
WP =	208 g	590	208	379		WP =	205 g	688	205	483
CP -	379 g	- 587	+ 1	+ 2		CP -	483 g	- 685	- 1	- 2
	587 g	3	209	381			688 g	3	209	381

Figure 2

weight of crankpin end of rod. Subtract 1.8 grams from weight of wristpin end of rod. Now both ends when added together equal actual total weight.

**CAUTION - Never subtract weight of one end of rod from actual total weight to get weight of other end of rod. An incorrect end weight used in this shortcut method can greatly affect balance and reverse final objective.**

N. Repeat procedure for rear rod.

**2. Calculate Weight of Bobweight**

All weights required to calculate bobweight to be used should be recorded on record sheet furnished. Perform calculations. See Figure 2 as an example showing calculations of a hypothetical balance job.

*NOTE - Figures shown are for purpose of illustration only. Do not use these figures in any balance computation: Use actual weights of parts to be used.*

**3. Assemble Bobweight**

A multiple piece bobweight composed of three parts is furnished with kit. **See Picture 1.** Main body has 23/8" diameter and is tapered to fit in crankpin hole. Bobweight retaining cap (11/2" diameter) secures bobweight in crankpin hole. Shim cap (23/8" diameter) screws into main body to hold shims in place. Bobweight without shims has been machined to weigh 1000 grams. An assortment of shims in varying thickness and weights is also furnished. These are bolted between shim retainer cap and main body to make up a bobweight equal to weight required to balance one flywheel. Number of shims furnished and weight of each one is:

2 shims .....	.185" thick .....	100.0 grams each
2 shims .....	.092" thick .....	50.0 grams each
5 shims .....	.025" thick .....	13.4 grams each
5 shims .....	.020" thick .....	10.8 grams each
5 shims .....	.015" thick .....	8.1.0 grams each
5 shims .....	.010" thick .....	5.4.0 grams each
5 shims .....	.005" thick .....	2.7.0 grams each

*NOTE - If no shims are used, a bobweight of as little as 1000 grams can be used. If as many shims as can be placed on screw of shim retainer cap and still thread retainer in main body, a bobweight of slightly over 1400 grams can be made. This range from 1000 to 1400 grams should be adequate to cover most engine builder's needs. If bob weights of less than 1000 grams are*

*required, main bobweight can be lightened by machining material evenly from flat surface.*

**CAUTION - Do not drill holes to lighten bobweight as this will change the center of gravity and cause erratic and inaccurate results.**

- A. Weigh main bobweight to be sure it equals 1000 grams.
- B. Subtract actual weight of main bobweight from balance weight required to balance one flywheel. Difference in weight must be made up of shims to be bolted between shim retaining cap and main body of main bobweight.
- C. Select combination of shims to obtain required weight, and check actual total weight by adding them one at a time to main bobweight on scales platform. Add heaviest weights first. Actual total weight should be within one gram of calculated weight.

*NOTE - Specific combinations of weights that equal commonly use bobweights (i.e. 4 1/4" stroke V<sup>2</sup> with cast pistons and S&S rods with alloy bearing cages) should be recorded for future reference. If discrepancies in weight from shim to shim exist, actual weight of each shim can be stamped on shim to simplify identification. Shim weight can be customized by cutting material from O.D. of extra ready made-shims, but material must be removed evenly from perimeter to avoid changing center of gravity of shim.*

**4. Assemble Flywheel for Balancing**

*NOTE - All balance components and flywheel mating surfaces such as mainshaft and crankpin tapers, etc. must be clean and free of metal filings and dirt to avoid damage to engine and balance parts.*

**CAUTION - Metal filings, dirt, or other material caught between flywheel and balance shaft and/or bobweight tapers may damage flywheel tapers which may make truing flywheels difficult during final assembly later.**

**WARNING - Some solvents, degreasers and other chemicals used for cleaning parts are harmful to skin, eyes and other body parts. Many items are flammable and present a fire hazard. Read manufacturer's instruction label for proper use. Use in well ventilated area and wear protective clothing when using them to avoid personal injury.**  
**All Engines With Two-Piece Mainshaft/Flywheels**



Picture 1

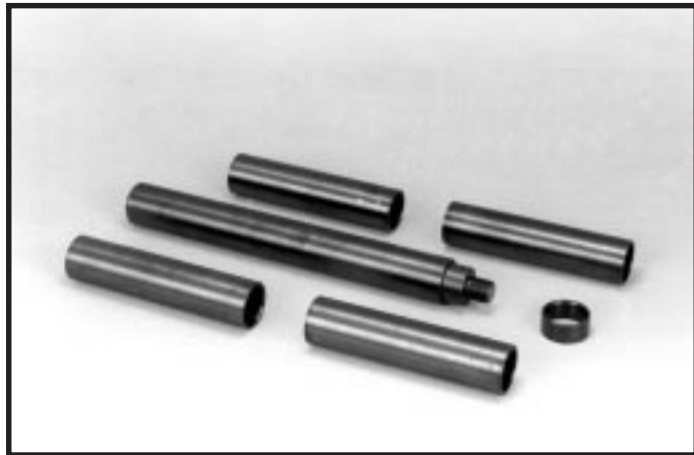

Picture 2

Balance shaft assembly used to balance flywheels in all engines with removable mainshaft consists of main balance shaft, two tapered spacers, and nut to secure flywheel to shaft. **See Picture 1.** Shaft with two different angled pressed-on tapers is used to do most flywheels with smaller diameter tapers. Removable tapered spacers can be added to one side of shaft or other to balance all flywheels with larger diameter tapers.

- Check keyway and oil hole in flywheel taper for burrs and remove if present.
- Clean flywheel, balance shaft and bobweight tapers with solvent.
- Select taper on shaft and taper spacer, if necessary, that fits mainshaft taper in flywheel to be balanced. Secure assembly in flywheel with balance shaft nut.
- Bolt bobweight assembly in crankpin hole.

#### All Engines With One Piece Mainshaft/Flywheels

In 1985 Harley-Davidson changed flywheel/mainshaft assembly design from multiple piece to single, one piece construction. S&S kit components used to balance these flywheels are a set of special adapter sleeves, two collar spacers and a counterweight. **See Picture 2** (one collar spacer not shown). Special adapter sleeve is screwed on shaft to act as bearing surface and counterweight adapter. Collar spacer is used on sprocket shaft to space adapter away from flywheel if timken bearing has been removed. Counterweight is screwed in adapter and offsets weight of flywheel and bobweight when assembly is placed on balance stand.

*NOTE - Some earlier two piece mainshaft/flywheel assemblies may also be balanced using these balancing components in lieu of disassembling them, rebalancing them and then reassembling them.*

#### Big Twin - Driveside

- Clean mainshaft bearing surface, flywheel crankpin taper, inside and outside of collar spacer #53-0097 and sleeve #53-0091, counterweight #53-0099 and bobweight taper with solvent.
- If timken bearing assembly has been removed, use collar #53-0097 to space sleeve #53-0091 away from flywheel.
- Slip sleeve #53-0091 on sprocket shaft. Screw sleeve on to sprocket shaft until sleeve contacts bearing or #53-0097 spacer. Hand tighten. Do not overtighten.
- Lay flywheel down with sleeve/shaft facing up and screw counterweight #53-0099 into end of sleeve until hand tight. Do not overtighten.
- Bolt bobweight assembly in crankpin hole.

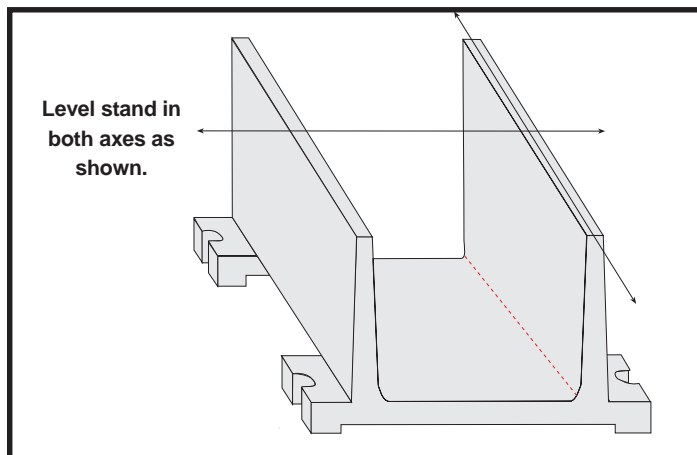

Figure 3

#### Big Twin - Camside

- Clean mainshaft bearing surface, flywheel crankpin taper, inside and outside of sleeve #53-0101, counterweight #53-0099 and bobweight taper with solvent.
- Slip sleeve #53-0101 on pinion shaft. Screw sleeve on shaft until it contacts flywheel, and handtighten. Do not over tighten.
- Lay flywheel down with sleeve/shaft facing up and screw counterweight #53-0099 into end of sleeve until hand tight. Do not over tighten.
- Bolt bobweight assembly in crankpin hole.

#### XL - Driveside

- Clean mainshaft bearing surface, flywheel crankpin taper, inside and outside of collar spacer #53-0098 or #53-0085 and sleeve #53-0093, counterweight #53-0099 and bobweight taper with solvent.
- If timken bearing assembly has been removed, slide collar #53-0098 for '86-'90 engines or collar #53-0085 for '91-up engines on sprocket shaft to space sleeve #53-0093, away from flywheel.
- Slip sleeve #53-0093 on sprocket shaft. Screw sleeve on shaft until it contacts spacer or timken bearing. Hand tighten only. Do not overtighten.
- Lay flywheel down with sleeve/shaft facing up and screw counterweight #53-0099 into end of sleeve until hand tight. Do not overtighten.
- Bolt bobweight assembly in crankpin hole.

#### XL - Camside

- Clean mainshaft bearing surface, flywheel crankpin taper, inside and outside of sleeve #53-0095, counterweight #53-0099 and bobweight taper with solvent.
- Slip sleeve #53-0095 on pinion shaft. Screw sleeve on shaft until it contacts flywheel and hand tighten. Do not overtighten.
- Lay flywheel down with sleeve/shaft facing up and screw counterweight #53-0099 into end of sleeve until hand tight. Do not overtighten.
- Bolt bobweight assembly in crankpin hole.

#### 5. Balance Stand

Balance stand shown in **Figure 3** has four mounting lugs so it can be bolted down. Bottom of lug pads and two narrow top edges have been surface ground. When stand is placed on a

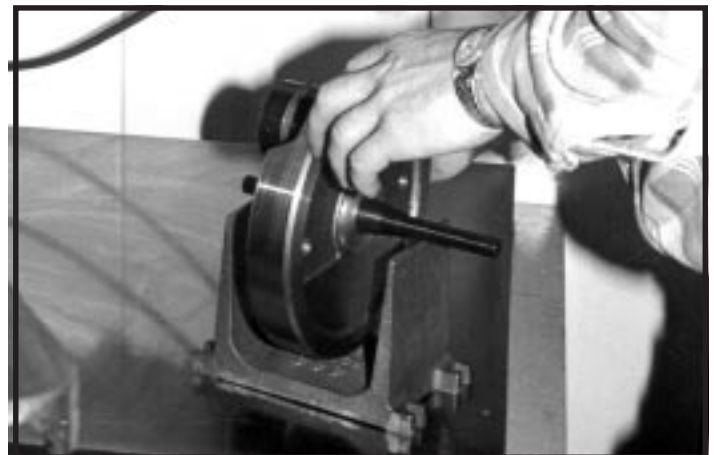

Picture 3

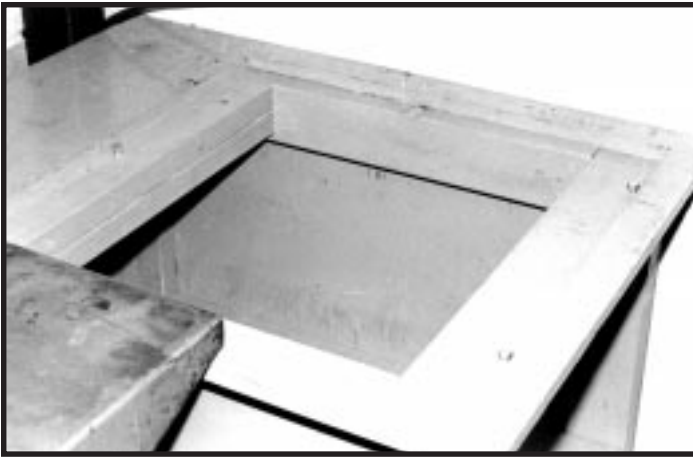

Picture 4

perfectly flat and level surface, narrow edges should be level in both axes as shown.

- A. Select unobstructed work surface or construct separate "balancing bench".

*NOTE - If many balancing jobs are to be performed, it is recommended that a special balancing bench be constructed. Building a separate bench cuts down balancing stand setup and leveling time, because bench isn't subjected to day to day abuses which can alter stand staying level.*

- B. Bolt stand to bench. Do not tighten bolts. If surface plate is used as in **Picture 3**, stand does not need to be bolted down.
- C. Shim under four corners as necessary to level stand in both directions as shown in **Figure 3**. If separate bench and surface plate combination is used, surface plate can be leveled using three leveling screws located under surface plate. **See Picture 4**. Level stand/plate by placing level on stand as in **Picture 5**. Turn stand with level on edges 90° and check.

*NOTE - Leveling is important and should be done as accurately as possible. Recheck before performing each balance job.*

## 6. Balancing Flywheels

- A. Gently place flywheel assembly to be balanced on balance stand. Position assembly with balance shaft installed between and in center of stand edges with bobweight at top. **See Picture 3**. Bobweight must clear

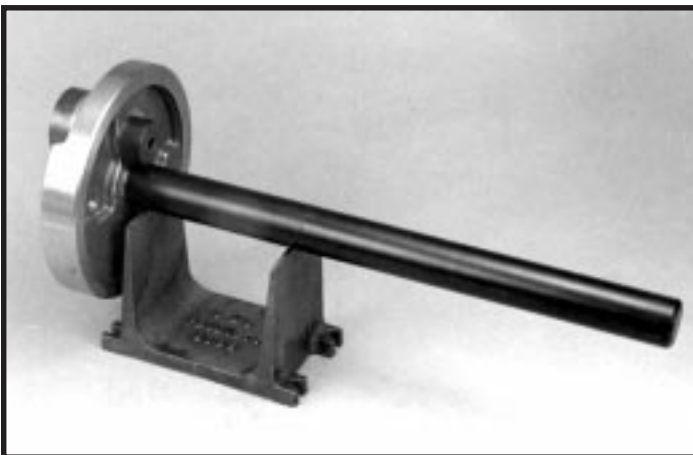

Picture 6



Picture 5

edge when allowed to rotate 360°. Assembly with sleeve and counterweight screwed on shaft place outside of stand edges but in center with bobweight at top. Counterweight must be perpendicular to parallels, and bobweight nut must clear stand throughout 360° of rotation. **See Picture 6**.

*NOTE - Balance stand and balance shaft should be handled with care so as not to nick or scratch stand edges or other balancing component surfaces.*

**CAUTION - Damaged components will cause unwarranted rolling resistance between parts often resulting in misleading readings and improper balance hole placement.**

- B. Heavy side of assembly (usually counterweight side of flywheel or side opposite bobweight) will rotate downward. When heavy point on flywheel has been determined, mark position on inside (connecting rod side of flywheel). Check to be sure heaviest spot has been selected by positioning spot 90° to right of downward position and then letting flywheel rotate. Recheck by positioning spot 90° to left of downward position and then letting flywheel rotate. Note each time how fast flywheel drops to heaviest position.
- C. Set drill press with table that can be moved up and down

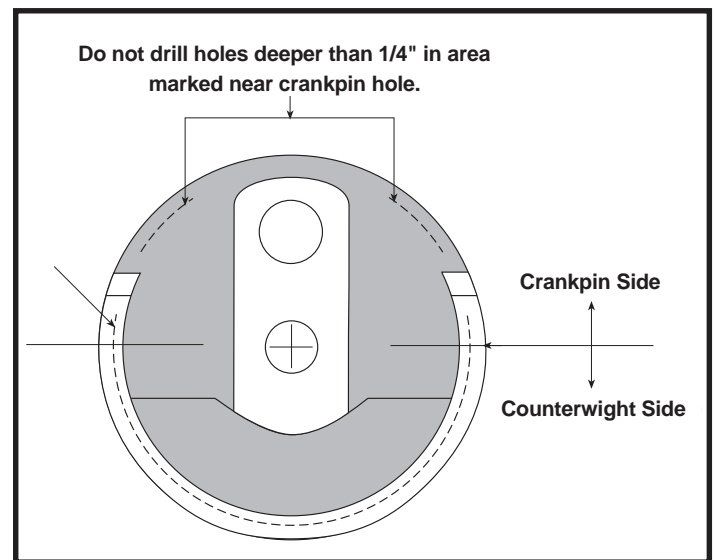

Figure 4

and swiveled from side to side so flywheel/bob weight assembly when placed with rod side up on table can be drilled around outer rim. Support as much of the assembly on drill press table as possible.

- D. Set drill depth so drill point stops  $\frac{5}{16}$ " above table. Use  $\frac{3}{8}$ " to  $\frac{7}{16}$ " dia. drill to drill holes in Sportster flywheels and  $\frac{7}{16}$ " to  $\frac{1}{2}$ " dia. drill for Big Twins.
- E. Before drilling see **Figure 4** for recommended areas to drill. See notes on page 7 for drilling rules and additional information.
- F. There is no formula to explain how many holes to drill or how deep holes should be. Experience is best teacher. After several balance jobs you may be able to judge how much material (how many holes to drill and how deep) must be removed from flywheel by how fast heavy spot rotates downward. When first starting and learning, drill hole about  $\frac{1}{4}$ " deep, then check, then drill again. Drill first hole at heaviest point to half depth. Drill additional holes, an equal number to identical depths, on each side of first hole. When flywheel is close to being balanced,  $\frac{1}{16}$ " depth of material in a  $\frac{1}{2}$ " diameter hole will make a big difference between assembly rotating or remaining stationary. If about  $\frac{1}{16}$ " is all that's left to remove, drill remaining amount from first hole. Assembly is in balance when heavy point is placed in three different positions on balance stand,  $120^\circ$  apart, and flywheel remains stationary and does not rotate.

*NOTE - If heavy spot continually changes position around circumference and flywheel still wants to rotate, more than likely balance stand/surface plate is not perfectly level, or balance shaft or balance stand surfaces are dirty, nicked or uneven.*

- G. Repeat process for other flywheel.

#### NOTES

- Drill holes in center of face along dotted line in diagram. (See **Figure 4**) Leave  $\frac{3}{16}$ " of material to avoid breaking out of back side of flywheel.
- Do not drill holes deeper than  $\frac{1}{4}$ " in areas marked near crankpin hole.
- When balancing stock H-D or other cast iron flywheels, drill holes  $\frac{1}{4}$ " minimum from outer edge of rim. Space holes  $\frac{1}{4}$ " apart.
- S&S forged steel flywheels are stronger. Holes can be drilled  $\frac{1}{8}$ " from outer rim and  $\frac{1}{8}$ " apart.
- Do not accept flywheels for rebalancing with holes drilled in unprescribed areas.
- Have flywheels magnafluxed to check for cracks if any doubt exists about structural integrity.

**CAUTION - Numerous holes and drilling holes in unprescribed areas may weaken flywheels causing them to break resulting in damage to engine.**

**WARNING - Weakened flywheels from improper balancing and being rebalanced too many times may explode during operation causing personal injury to you or others around you.**

- Before drilling, check opposite side of flywheel for old balance holes. Do not drill into old holes.
- If drilling must be done in crankpin side of flywheel and there are holes in counterweight side, fill holes in counterweight side

first before balancing. There are several ways to do this:

#### Solder method

1. Tap holes.
2. Heat holes with propane torch.
3. Fill holes with acid core solder.
4. Use punch or chisel to stake threads to insure that solder can not come out of threaded hole during engine operation.

#### Threaded rod method

1. Tap holes.
2. Screw a bolt or threaded rod into holes. Use loctite or similar thread locking compound to insure that threaded rod can not come out of threaded hole during engine operation.
3. Cut threaded rod off and grind or machine flush with surface of flywheel.

*Filling holes makes counterweight side heavier thereby reducing number of holes required to balance flywheel.*

- When balancing flywheels to very heavy bob weights, it is sometimes necessary to machine holes in counterweight of flywheel and press in slugs of Mallory metal tungsten alloy (sometimes called heavy metal). To determine the amount of Mallory to add to counterweight, remove weights from bobweight until flywheel could be balanced to the lightened bobweight by normal drilling method. Note amount of weight removed, and replace weights on bobweight. One half amount of weight removed from bobweight must be added to flywheel counterweight.

Example:

If 200 gm is removed from bobweight, 100 gm must be added to counterweight.

Slug size can be estimated using the following:

- 1.000" Diameter X 1.100" long adds about 100gm
- .500" Diameter X 1.100" adds about 25gm

Mallory metal is available from:

M. I. Tech Metals  
1340 North Senate Ave  
Indianapolis, IN 46202  
1-800-624-1895

#### Conclusion

We feel that excellent results can be obtained using this kit to statically balance flywheels. As proficiency increases, actual balancing can be done in a matter of minutes. Weighing parts and calculating weight of bobweight to be used will actually take longer.

Included are two copies of a record form we developed and urge you to use. Make copies of this form and use them (save the original to make copies). It is interesting to review these records from time to time and note similarities and trends.

The material in this instruction sheet should equip the engine builder with a basic understanding of balancing. There are many technical aspects that would fill books on the subject, but for the average shop application, further discussion is not necessary.

# Balance Kit Replacement Parts

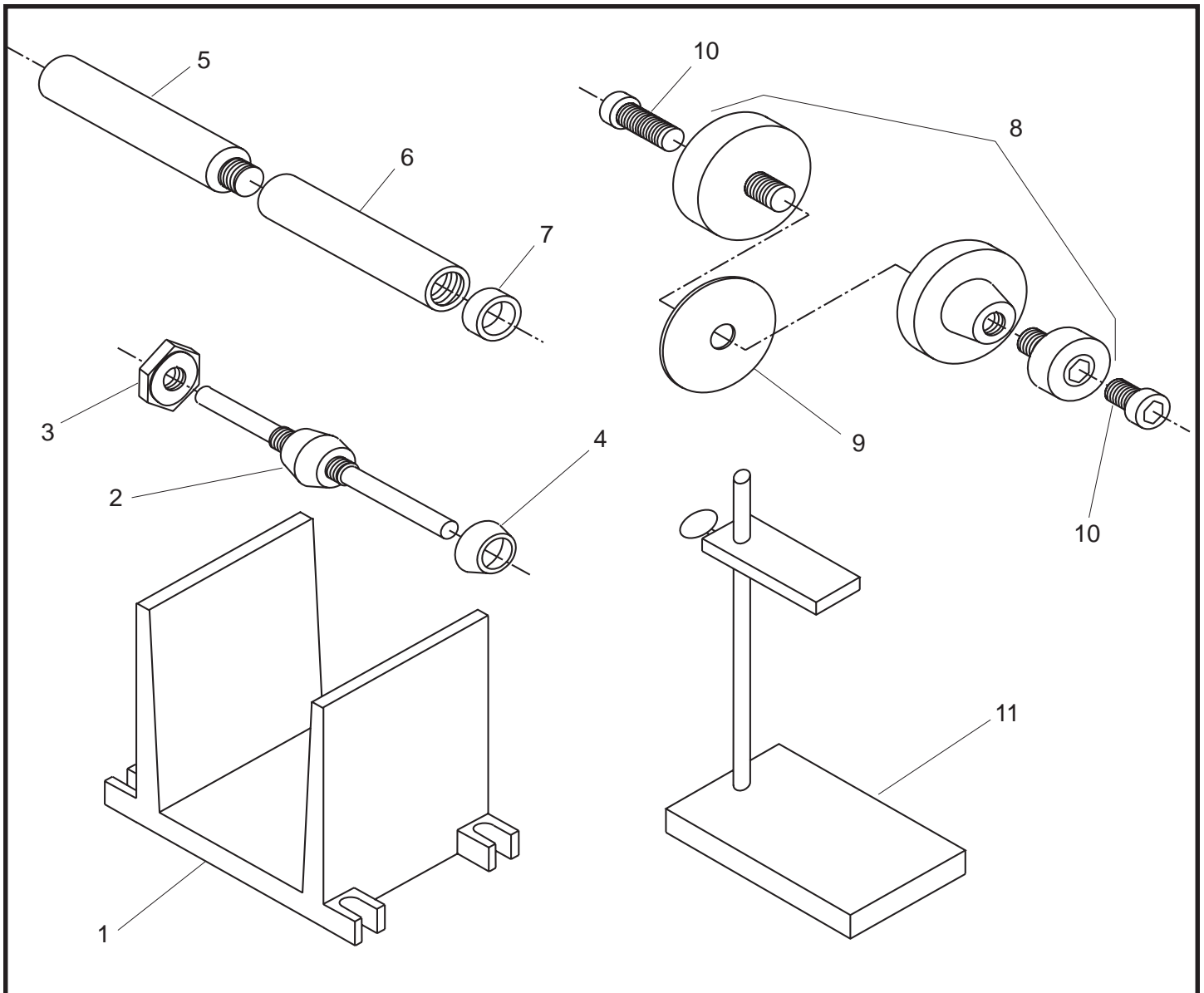

- |  |               |   |               |
|--|---------------|---|---------------|
| 1. Balance stand.....  | Part #53-0088 | 8. Bobweight - 1000 gr(no shims included) . | Part #53-0094 |
| 2. Balance shaft .....                                       | Part #53-0090 | 9. Bobweight shims:                         |               |
| 3. Balance shaft nut .....                                   | Part #53-0092 | 2.7 gr.....                                 | Part #53-0105 |
| 4. Taper adapters:   |               | 5.4 gr.....                                 | Part #53-0110 |
| Taper adapter, BT '72-E'81 .....                             | Part #53-0086 | 8.1 gr.....                                 | Part #53-0115 |
| Taper adapter, Late'81- up all .....                         | 53-0087       | 10.8 gr.....                                | Part #53-0120 |
| 5. Adapter sleeve counter weight (all V <sup>2</sup> ) ..... | Part #53-0099 | 13.4 gr.....                                | Part #53-0125 |
| 6. Adapter sleeves:  |               | 50 gr.....                                  | Part #53-0150 |
| Driveside adapter sleeve (all BT) .....                      | Part #53-0091 | 100 gr.....                                 | Part #53-0100 |
| Camside adapter sleeve (BT 1970-1992) ....                   | Part #53-0101 | 10. Bolts for bobweights                    |               |
| Camside adapter sleeve (BT 1993-up) .....                    | Part #53-0102 | ½-13 x 1¼" .....                            | Part #50-0201 |
| Driveside adapter sleeve ( all V <sup>2</sup> XL).....       | Part #53-0093 | ½-13 x ¾" .....                             | Part #50-0200 |
| Camside adapter sleeve (all V <sup>2</sup> XL) .....         | Part #53-0095 | 11. Adjustable rod support stand .....      | Part #53-0089 |
| 7. Driveside collar spacers:                                 |               | 12. Platform gram scales (Not Shown) .....  | Part #53-0011 |
| Collar spacer (all BT).....                                  | Part #53-0097 |   |               |
| Collar spacer (V <sup>2</sup> XL 1986-1990) .....            | Part #53-0098 |   |               |
| Collar spacer (V <sup>2</sup> XL 1991 - up) .....            | Part #53-0085 |   |               |

Owner's Name: \_\_\_\_\_

**Date:**  
\_\_\_\_\_

**Big Twin**      
**Sportster**   

**Year of Engine**  
\_\_\_\_\_

**Bore**  
\_\_\_\_\_

**Stroke**  
\_\_\_\_\_

**Rod Type**  
\_\_\_\_\_

**Cage Type**  
\_\_\_\_\_

**Front Piston Weight**  
Piston \_\_\_\_\_  
Wristpin \_\_\_\_\_  
Clips \_\_\_\_\_  
Rings \_\_\_\_\_  
**Total** \_\_\_\_\_

**Rear Piston Weight**  
Piston \_\_\_\_\_  
Wristpin \_\_\_\_\_  
Clips \_\_\_\_\_  
Rings \_\_\_\_\_  
**Total** \_\_\_\_\_

**Total of Both** \_\_\_\_\_

**Connecting Rods**  
Crankpin \_\_\_\_\_  
Nuts \_\_\_\_\_  
Cages \_\_\_\_\_  
Bearings \_\_\_\_\_  
Nut Locks & Screws \_\_\_\_\_  
**Total** \_\_\_\_\_

**Front Rod**  
WP End \_\_\_\_\_  
CP End \_\_\_\_\_  
**Total** \_\_\_\_\_  
**Act. Wt.** \_\_\_\_\_

**Rear Rod**  
WP End \_\_\_\_\_  
CP End \_\_\_\_\_  
**Total** \_\_\_\_\_  
**Act. Wt.** \_\_\_\_\_

**Reciprocating Weight**  
**Total of Both Pistons** \_\_\_\_\_  
WP End of Front Rod \_\_\_\_\_  
WP End of Rear Rod \_\_\_\_\_  
**Total Reciprocating Weight** \_\_\_\_\_

**Rotating Weight**  
**Total of Crankpin, Nuts, etc.** \_\_\_\_\_  
CP End of Front Rod \_\_\_\_\_  
CP End of Rear Rod \_\_\_\_\_  
**Total Rotating Weight** \_\_\_\_\_

**Total Recipocating Weight** \_\_\_\_\_  
**Multiply Times Balance Factor** \_\_\_\_\_  
**Recipocating Weight** \_\_\_\_\_  
**Add Total Roating Weight** \_\_\_\_\_  
**Total Bobweight for 2 Wheels** \_\_\_\_\_  
**Divide By 2** \_\_\_\_\_

**Total Weight of Bobweight to Be Used on Each Flywheel** \_\_\_\_\_

NOTES:

Owner's Name: \_\_\_\_\_

**Date:**  
\_\_\_\_\_

**Big Twin**      
**Sportster**   

**Year of Engine**  
\_\_\_\_\_

**Bore**  
\_\_\_\_\_

**Stroke**  
\_\_\_\_\_

**Rod Type**  
\_\_\_\_\_

**Cage Type**  
\_\_\_\_\_

**Front Piston Weight**  
Piston \_\_\_\_\_  
Wristpin \_\_\_\_\_  
Clips \_\_\_\_\_  
Rings \_\_\_\_\_  
**Total** \_\_\_\_\_

**Rear Piston Weight**  
Piston \_\_\_\_\_  
Wristpin \_\_\_\_\_  
Clips \_\_\_\_\_  
Rings \_\_\_\_\_  
**Total** \_\_\_\_\_

**Total of Both** \_\_\_\_\_

**Connecting Rods**  
Crankpin \_\_\_\_\_  
Nuts \_\_\_\_\_  
Cages \_\_\_\_\_  
Bearings \_\_\_\_\_  
Nut Locks & Screws \_\_\_\_\_  
**Total** \_\_\_\_\_

**Front Rod**  
WP End \_\_\_\_\_  
CP End \_\_\_\_\_  
**Total** \_\_\_\_\_  
**Act. Wt.** \_\_\_\_\_

**Rear Rod**  
WP End \_\_\_\_\_  
CP End \_\_\_\_\_  
**Total** \_\_\_\_\_  
**Act. Wt.** \_\_\_\_\_

**Reciprocating Weight**  
**Total of Both Pistons** \_\_\_\_\_  
WP End of Front Rod \_\_\_\_\_  
WP End of Rear Rod \_\_\_\_\_  
**Total Reciprocating Weight** \_\_\_\_\_

**Rotating Weight**  
**Total of Crankpin, Nuts, etc.** \_\_\_\_\_  
CP End of Front Rod \_\_\_\_\_  
CP End of Rear Rod \_\_\_\_\_  
**Total Rotating Weight** \_\_\_\_\_

**Total Recipocating Weight** \_\_\_\_\_  
**Multiply Times Balance Factor** \_\_\_\_\_  
**Recipocating Weight** \_\_\_\_\_  
**Add Total Roating Weight** \_\_\_\_\_  
**Total Bobweight for 2 Wheels** \_\_\_\_\_  
**Divide By 2** \_\_\_\_\_

**Total Weight of Bobweight to Be Used on Each Flywheel** \_\_\_\_\_

NOTES: